

12mm方型(按入式)

具有稳定操作感的连接式轴感和和平面轴杆。

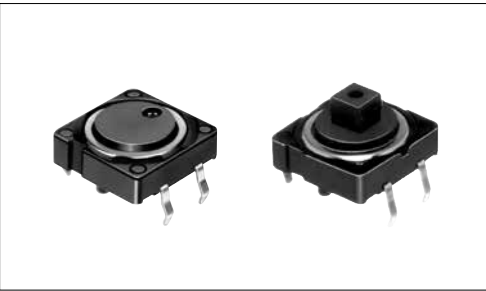

主要规格

项目	规格
最大额定	50mA 12V DC
最小额定	10 μ A 1V DC
初期接触电阻	100m max.
行程 (mm)	0.3

产品一览

产品编号	动作力	操作方向	操作寿命 (5mA 5V DC)	按钮颜色	按钮	最小订货单位 (pcs.)		图号
						日本	出口	
SKHCBJA010	0.74N	Top push	500,000 cycles	Blue	Joint stem type	1,000	1,000	1
SKHCBEA010	1.27N		1,000,000 cycles	Black				
SKHCBGA010	2.55N		500,000 cycles	Dark gray				
SKHCBKA010	0.74N		Flat stem type	500,000 cycles	Blue			2
SKHCBFA010	1.27N			1,000,000 cycles	Black			
SKHCBHA010	2.55N			500,000 cycles	Dark gray			

包装规格 散装

外形图

No.	照片	形状	印刷电路板安装孔尺寸图 (自开关安装面看)
1	Joint stem type		

12mm方型(按入式)

外形图

Unit:mm

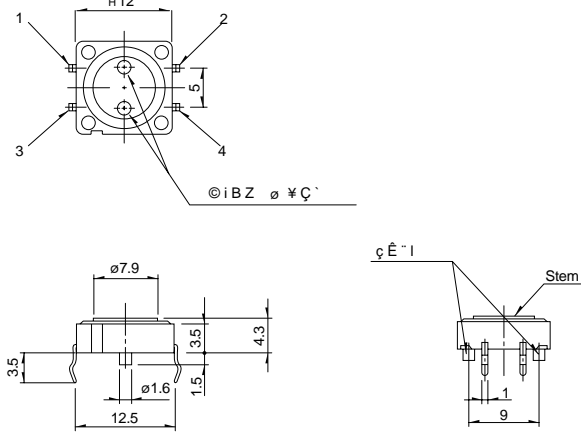
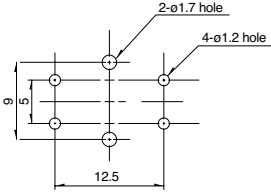
No.	照片	形状	印刷电路板安装孔尺寸图 (自开关安装面看)
2			

注

请使用 1.6mm 板厚的印刷电路板。

电路图

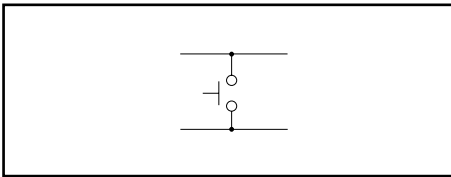

旋钮产品一览表

Unit:mm

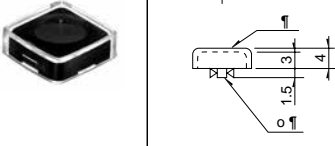
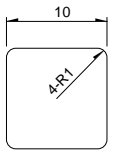
安装可能机种名	外形图	种类		插入标签外形图
		颜色	产品名	
SKHC SKQE 适用 Joint stem type		端帽		
		Clear	SK2AA00510	
		键帽		键帽+端帽
		Red Blue Ivory Black	SK2AA00010 SK2AA00020 SK2AA00030 SK2AA00040	SK2AA00060 SK2AA00070 SK2AA00080 SK2AA00090
				Thickness 0.1

注

1. 旋钮以没有安装在开关上的状态同时交货。
2. 没有准备插入标签。
3. SK2AA00010~SK2AA00090型, 请确认安装方向。

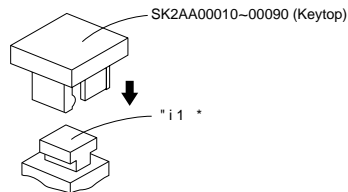

í@oH
a"¿VëL ~
Ñ sf

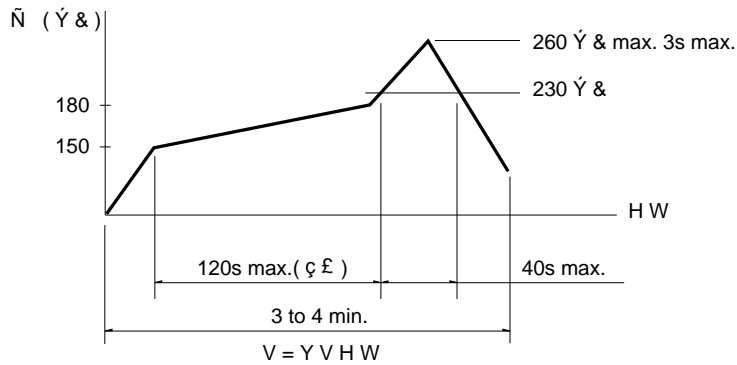

ÿ

1¿W% Hq h¿' ³¥ÁÖ?i€É, 'ab
ô Lëoø¥ÖË Hq,]²T,] hY5 sÉ, 'a-aP~b

1îïoH
a"¿¿ÆT á_~

["	H q
ùo4, "	,, "¿, †qL ë¥ñ
ç£Ñ	†—É^ðoαë¥Ů¶Ñ ¥ NBY
ç£Ñ HW	T NBY
oαÑ	¥ NBY
oαİ2HW	T NBY
oαQ"	UJNFT NBY

["	H q
oαÑ	¥ NBY
oαİ2HW	T NBY
o4ö,	8 NBY

SKHH, SKHW "

["	H q
oαÑ	¥ NBY
oαİ2HW	T NBY
o4ö,	8 NBY

SKTD SKTG SKQJ "

["	H q
oαÑ	¥ NBY
oαİ2HW	T NBY
o4ö,	8 NBY

oαÑ	¥ NBY
oαİ2HW	T NBY
oαQ"	UJNFT NBY

SKHL5PQ QVTISKQJ "

["	H q
ùo4, "	

ÿ

h,1V5"\$5 4XJŮDlëiÆùo4b
h,1Y- 71 0#†—É^ð¥,†qL ë pùo4b
É» QoαH < 71i~žÉÑ-aÉ>b
hP~1x' [¥ùo4 éTô Bh&\$Tí &\$ 4]©Öb